

Verfahrenskonzept zur Entfettung von Bandstahl

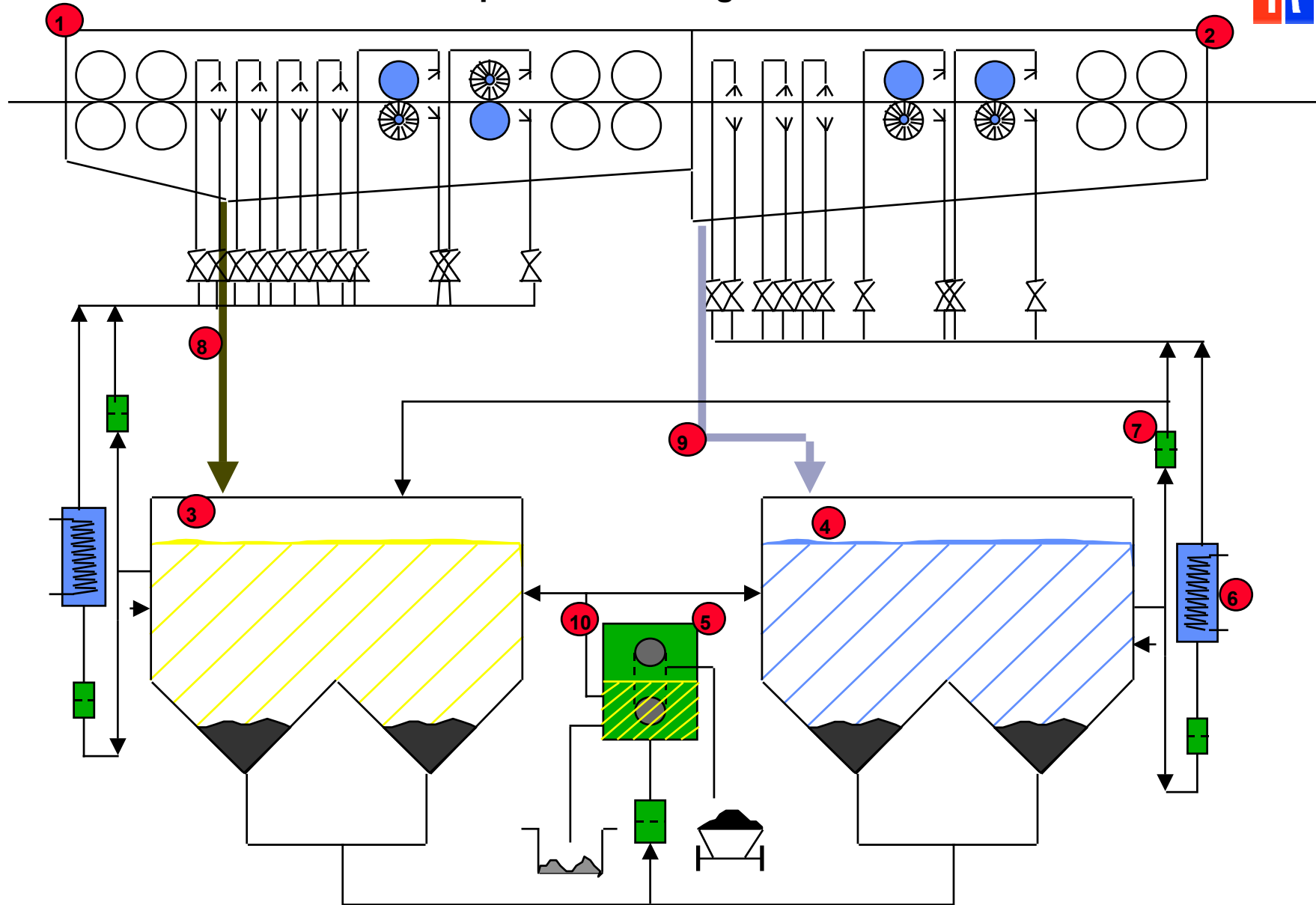

Verfahrensvorschlag zur Entfettung von Bandstahl

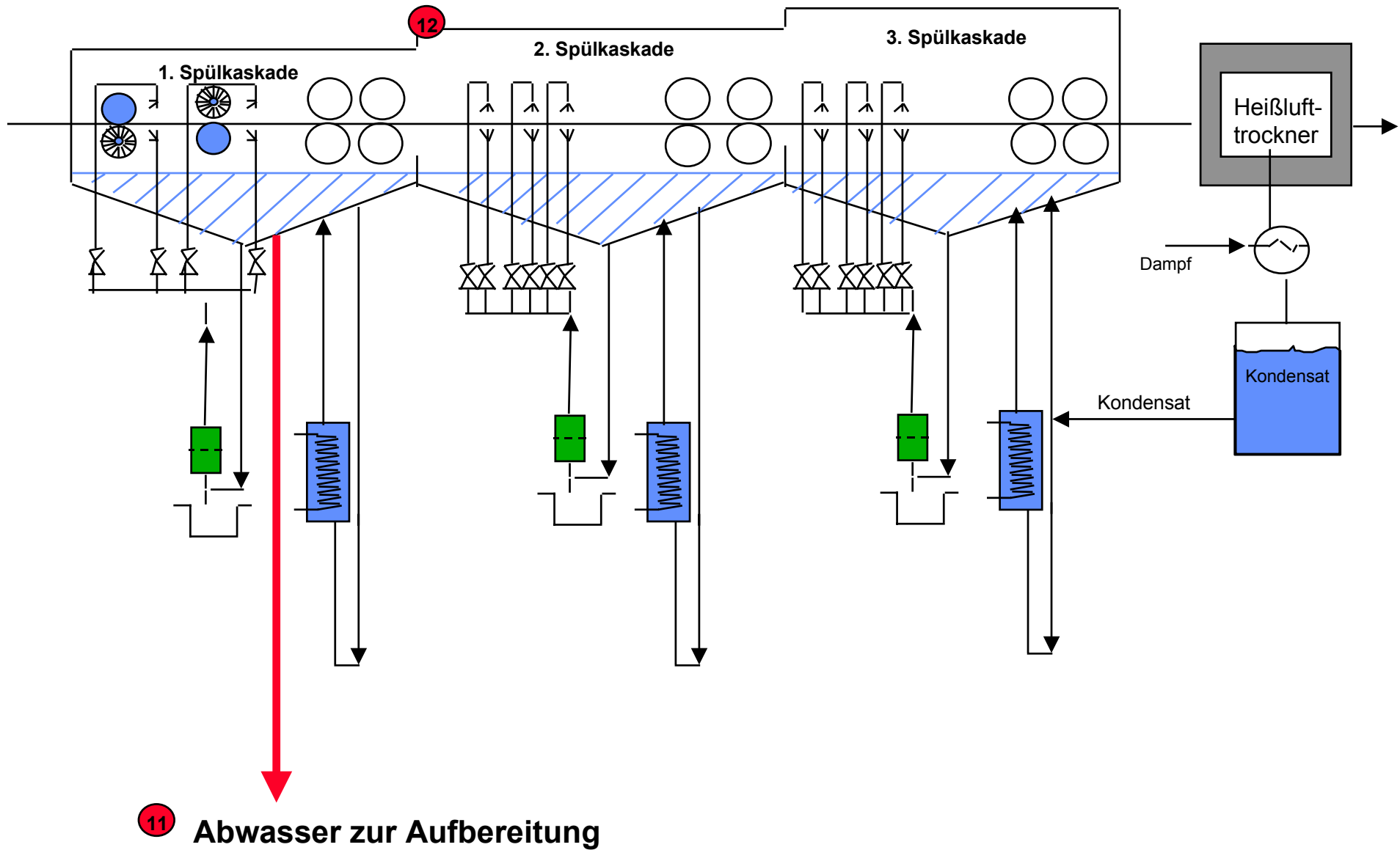

Mikrofiltration zur Badstandzeitverlängerung

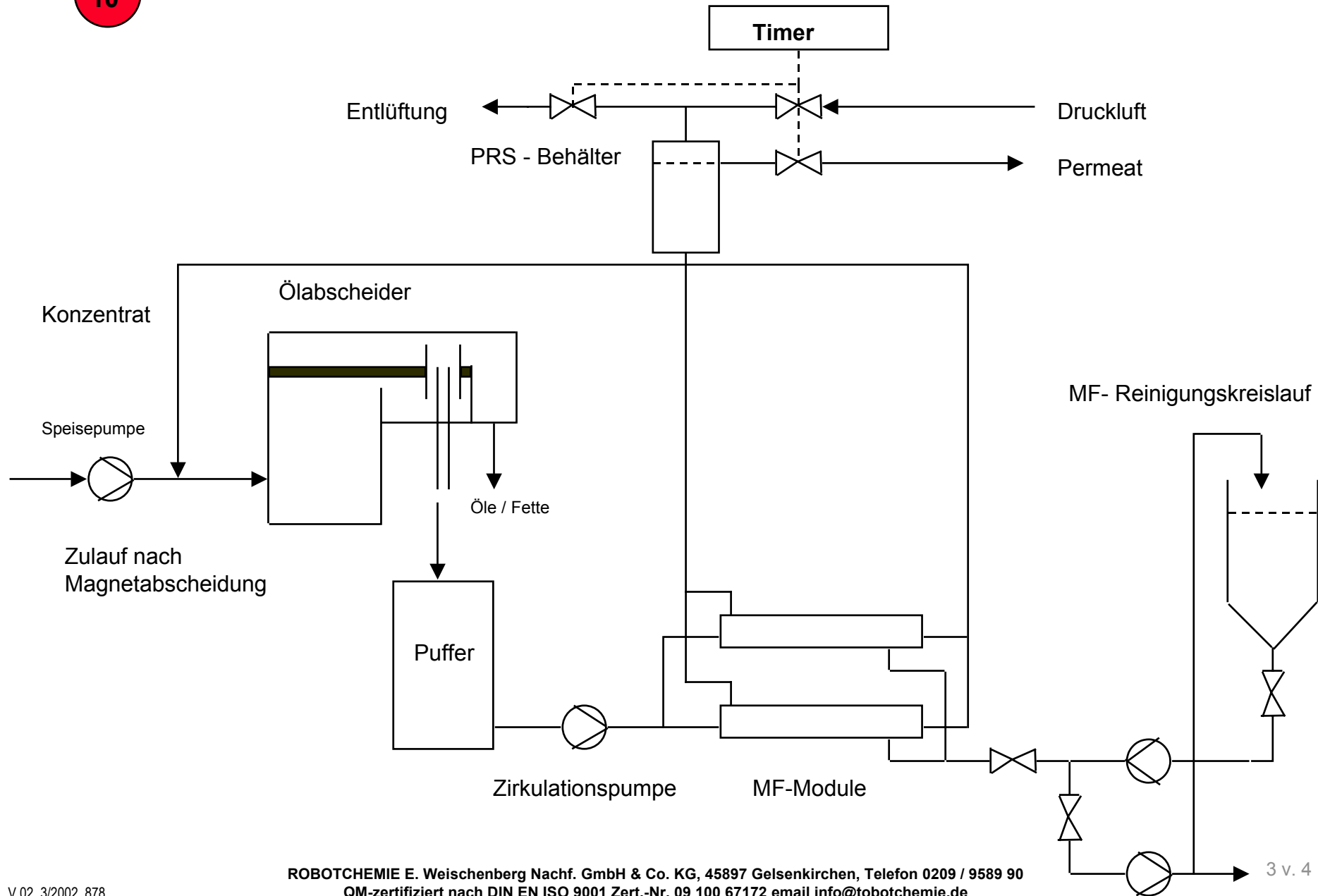

Umkehrosmose - Ein Verfahren zur Gewinnung von Reinstwasser

